

# CILINDRO COMPACTO AFO DE 2 1/2" DE DIÁMETRO

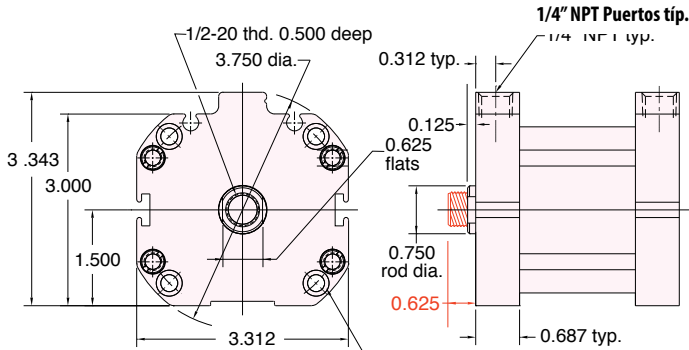

AF-□ □ □ -40- □



Mounting holes for 0.250 socket head cap screw (4) p/ces equally spaced on 3.250 dia. bolt circle



Para vástago con cuerda macho añada al final del número de parte -T  
Para nomenclatura **ver página 78.**

## ESTILOS DE MONTAJE

Cinco estilos de montaje le dan instalación versátil, rápida y sencilla.

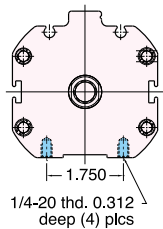

**Montaje inferior**  
AF-Bxx-40-x

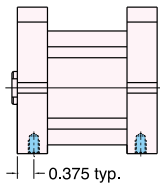

**Montaje universal**  
AF-Uxx-40-x

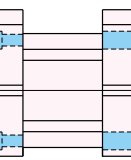
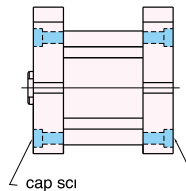

**Montaje frontal**  
AF-Fxx-40-x

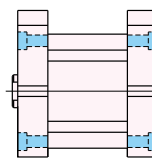

**Montaje trasero**  
AF-Rxx-40-x

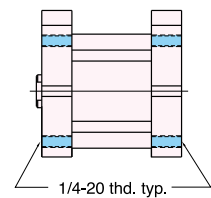

**Montaje con roscas**  
AF-Txx-40-x

## LONGITUDES DE CILINDRO

"L"	Carrera	Simple Efecto	Acción Inversa
L1	1/4" - 1"	1 3/16"	
L1	1 1/8" - 2"	2 1/16"	
L1	2 1/8" - 3"	2 15/16"	
L1	3 1/8" - 4"	3 13/16"	
L2	1/4" - 1"		1 15/16"
L2	1 1/8" - 2"		2 13/16"
L2	2 1/8" - 3"		3 11/16"
L2	3 1/8" - 4"		4 9/16"

Longitud total del cuerpo es carrera más "L"

**Añade 7/8" para pistón magnético**

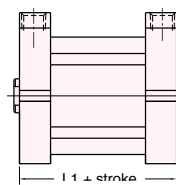

**L1 + carrera**  
Simple efecto  
AF-xSR-40x

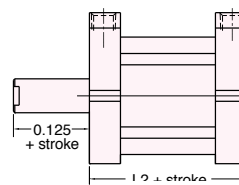

**L2 + carrera**  
Acción inversa  
AF-xRR-40x

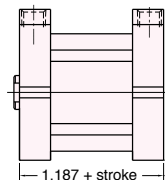

**0.875 + carrera**  
Cilindro de doble efecto  
Vástago sencillo  
AF-xDR-40-x

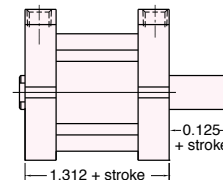

**0.937 + carrera**  
Doble efecto  
Doble vástago  
AF-xDD-40-x

Fuerzas del resorte	
<b>Simple Efecto</b>	
En Compresión	En reposo
25 lbs.	18.5 lbs.
<b>Acción Inversa</b>	
En Compresión	En reposo
25 lbs.	18.5 lbs.